

90CM TELESCOPIC HOOD AT1349X

Brandt
Innovations you need

SPECIFICATIONS

Mechanical structure

- Telescopic
- Stainless steel
- 90cm
- Evacuation or Re-cycling mode

Control panel

- Mechanical slider control

Functions

- Max. airflow: 400m³/h
- 3 speed levels
- 48dBa at level 1

Lighting

- 2 x lamp lighting

Filters

- 2 x aluminum filters
- Charcoal filter (provided in re-cycling mode)

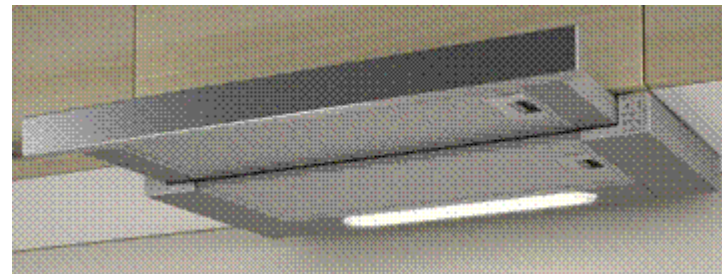

90CM TELESCOPIC HOOD AT1349X

Brandt
Innovations you need

ELECTRICAL CONNECTIONS

Electric Connections

- Total power (W): 186
- Current (A): 10
- Voltage (V): 220 - 240
- Frequency (Hz): 50 /60
- Length of electrical supply cord (cm): 130
- Type of plug: Without

DIMENSIONS

- Dimension of overall product (mm): H175 x W900 x D450
- Net weight (kg): 11
- Gross weight (kg): 12.5

**90CM TELESCOPIC HOOD
AT1349X**

Brandt
Innovations you need

INSTALLATION DIAGRAM

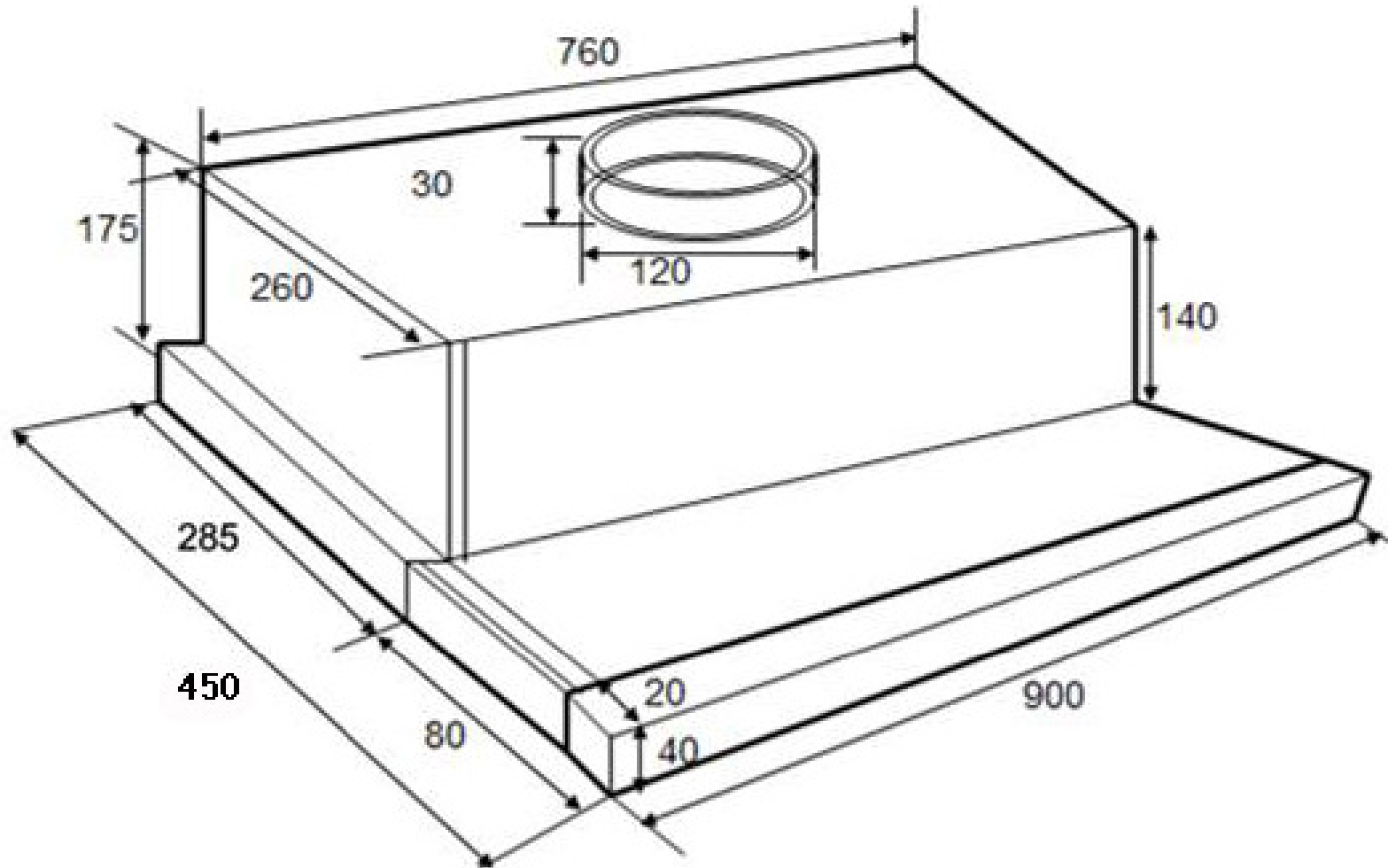

Installation: Ventilation Airflow for Telescopic hood AT1349 (with grill)

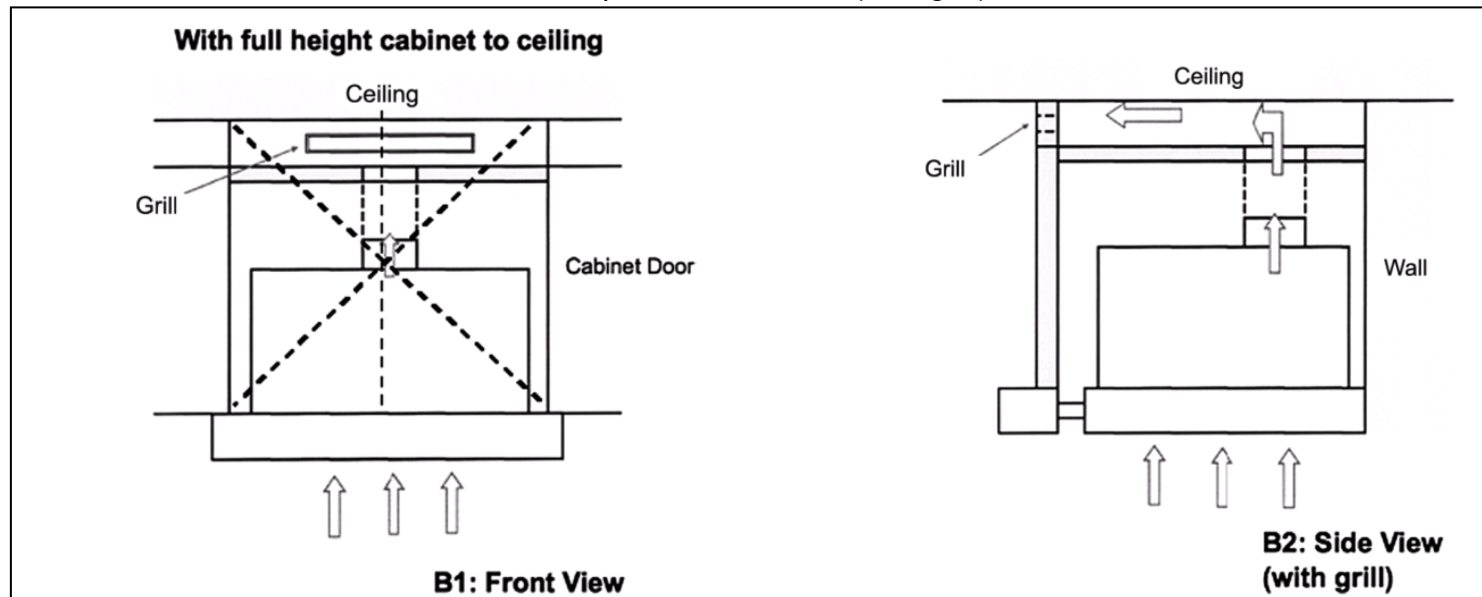

Installation: Ventilation Airflow for Telescopic hood AT1349 (without grill)

